

1-1470108-6 ✓ ACTIVE

TE Internal #: 1-1470108-6

PCB Mount Header, Right Angle, Wire-to-Board, 16 Position, 2 mm
[.079 in] Centerline, Fully Shrouded, Tin, Through Hole - Solder,
Signal, Natural

[View on TE.com >](#)



Connectors > PCB Connectors > PCB Headers & Receptacles > AMP HPI 2.0MM HEADERS

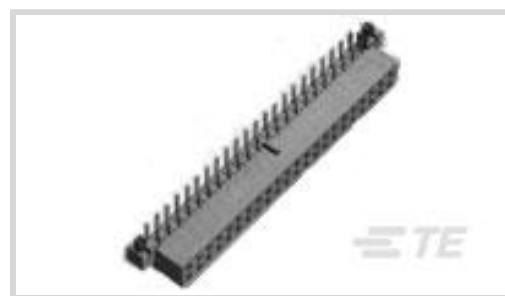

Connector System: **Wire-to-Board**

Number of Positions: **16**

Number of Rows: **2**

Centerline (Pitch): **2 mm [.079 in]**

PCB Mount Orientation: **Right Angle**

[All AMP HPI 2.0MM HEADERS \(211\)](#)

Features

Product Type Features

Connector System	Wire-to-Board
Header Type	Fully Shrouded
Sealable	No
Connector & Contact Terminates To	Printed Circuit Board
PCB Connector Assembly Type	PCB Mount Header

Configuration Features

Connector Contact Load Condition	Fully Loaded
Number of Positions	16
Number of Rows	2
PCB Mount Orientation	Right Angle

Electrical Characteristics

Insulation Resistance	5000 MΩ
Operating Voltage	100 VDC

Body Features

Primary Product Color	Natural
-----------------------	---------

Contact Features

Contact Mating Area Length	3.5 mm[.138 in]
----------------------------	-----------------



Mating Square Post Dimension	.5 mm[.02 in]
	100 μin
Contact Mating Area Plating Material Thickness	2.54 μm[100 μin]
Contact Shape & Form	Square
PCB Contact Termination Area Plating Material	Tin
Contact Base Material	Copper Alloy
Contact Mating Area Plating Material	Tin
Contact Type	Pin
Contact Current Rating (Max)	3 A

Termination Features

Square Termination Post & Tail Dimension	.5 mm[.02 in]
Terminations per Post (Max)	3
Termination Post & Tail Length	3 mm[.118 in]
Termination Method to Printed Circuit Board	Through Hole - Solder

Mechanical Attachment

Mating Alignment Type	Keyed
Mating Retention	Without
Connector Mounting Type	Board Mount
Mating Alignment	With
PCB Mount Alignment	Without
PCB Mount Retention	Without

Housing Features

Housing Material	High Temperature Thermoplastic
Centerline (Pitch)	2 mm[.079 in]

Dimensions

PCB Thickness (Recommended)	1.57 mm[.062 in]
Row-to-Row Spacing	2 mm[.079 in]

Usage Conditions

Operating Temperature Range	-25 – 85 °C[-13 – 185 °F]
-----------------------------	---------------------------

Operation/Application

Circuit Application	Signal
---------------------	--------

Industry Standards



Approved Standards	CSA LR7189, UL E28476
UL Flammability Rating	UL 94V-0

Packaging Features

Packaging Type	Loose Piece
----------------	-------------

Other

Position Locations Omitted	0
----------------------------	---

Product Compliance

[For compliance documentation, visit the product page on TE.com>](#)

EU RoHS Directive 2011/65/EU	Compliant
EU ELV Directive 2000/53/EC	Compliant
China RoHS 2 Directive MIIT Order No 32, 2016	No Restricted Materials Above Threshold
EU REACH Regulation (EC) No. 1907/2006	Current ECHA Candidate List: JUNE 2022 (224) Candidate List Declared Against: JUNE 2022 (224) Does not contain REACH SVHC
Halogen Content	Low Halogen - Br, Cl, F, I < 900 ppm per homogenous material. Also BFR/CFR/PVC Free
Solder Process Capability	Wave solder capable to 240°C

Product Compliance Disclaimer

This information is provided based on reasonable inquiry of our suppliers and represents our current actual knowledge based on the information they provided. This information is subject to change. The part numbers that TE has identified as EU RoHS compliant have a maximum concentration of 0.1% by weight in homogenous materials for lead, hexavalent chromium, mercury, PBB, PBDE, DBP, BBP, DEHP, DIBP, and 0.01% for cadmium, or qualify for an exemption to these limits as defined in the Annexes of Directive 2011/65/EU (RoHS2). Finished electrical and electronic equipment products will be CE marked as required by Directive 2011/65/EU. Components may not be CE marked. Additionally, the part numbers that TE has identified as EU ELV compliant have a maximum concentration of 0.1% by weight in homogenous materials for lead, hexavalent chromium, and mercury, and 0.01% for cadmium, or qualify for an exemption to these limits as defined in the Annexes of Directive 2000/53/EC (ELV). Regarding the REACH Regulation, the information TE provides on SVHC in articles for this part number is based on the latest European Chemicals Agency (ECHA) 'Guidance on requirements for substances in articles' posted at this URL: <https://echa.europa.eu/guidance-documents/guidance-on-reach>

Compatible Parts

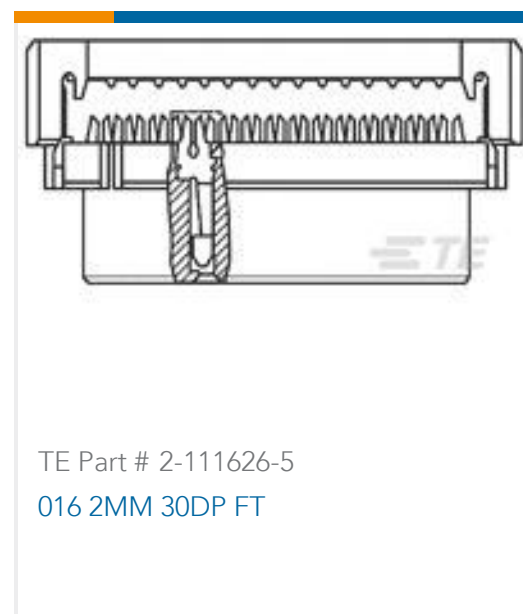

Documents

Product Drawings

2.0MM PITCH HEADER,DIP 16P

English

CAD Files

Customer View Model

[ENG_CVM_CVM_1-1470108-6_F.2d_dxf.zip](#)

English

3D PDF

3D

Customer View Model

[ENG_CVM_CVM_1-1470108-6_F.3d_igs.zip](#)

English

Customer View Model

[ENG_CVM_CVM_1-1470108-6_F.3d_stp.zip](#)

English

By downloading the CAD file I accept and agree to the [Terms and Conditions](#) of use.

Datasheets & Catalog Pages

AMPMODU_INTERCONNECTION_SYSTEM_SECTION3AND4

English

HPI Connectors QRG

English

Product Specifications

AMP 2.0mm PITCH EMIX Economic Metric Interconnect Series, Wire-To-Board System.

English

Application Specification

English